

EURO BOX CARTS

Robust:

400 kg capacity due to stable tubular and sectional steel construction and high-quality castors.

Selves:

Can be bolted in a 100 mm grid, either horizontal or inclined. Support struts for easier loading and unloading.

**4 TPE swivel castors:**

High-quality non-marking fetra TPE tyres with groove ball bearing. High manoeuvrability due to 4 swivel castors.

Euro box rollers

Suitable for Euro boxes 600 x 400 mm, powder coated, blue RAL 5007, 4 swivel castors with TPE tyres, hubs with groove ball bearing. 2 swivel castors with wheel locks.

13580 | 13680

Open angle steel construction.

13585

Steel plate tray leak-proof welded. Rim 22 mm high. Especially adapted for the transport of open-worked boxes with lubricated or wet parts. Nothing drips on the floor.

13581

With platform made of derived timber boards, rim 15 mm high.

13582

With platform made of derived timber material board, flush with frame.

13590

Box roller made of plastic (ABS 1st choice). Colour blue. 4 swivel castors, 2 swivel castors with wheel locks, wheels made of polyamide, hubs with glide bearing. Flat packed delivery.

Insertable shaft**13560**

insertable shaft for 13580 | 13581 | 13585 | 13680.

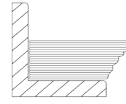
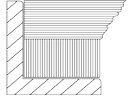
**13580 | 13680****13585****13581****13582****13590****13560**

	Order no.	Capacity kg	Wheel-Ø mm	Platform size L x W mm	Loading height mm	Type	Net weight kg
Euro box rollers	13580	250	125	605 x 405	182	open frame	9
	13680	250	125	810 x 610	182	open frame	11
	13585	250	125	605 x 405	182	steel plate platform	13
	13581	250	125	605 x 405	194	with boards	11
	13582	250	125	605 x 405	209	with boards	12
	13590	250	100	605 x 405	145	open frame	4
	13560	-	-	-	-	-	1,4

Euro boxes on page 100

Accessories
on pages 184-185

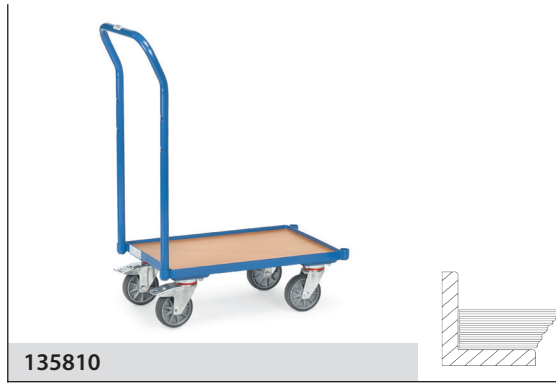

Euro box rollers

with push handle. Suitable for Euro boxes 600 x 400 mm, powder coated, blue RAL 5007, 4 swivel castors with TPE tyres, hubs with groove ball bearing. 2 swivel castors with wheel locks.

135800

Open angle steel construction.

135810

With platform made of derived timber boards, rim 15 mm high.

135820

With platform made of derived timber material board, flush with frame.

13587

Open angle steel construction with tubular push bar. The face end of the frame opposite the push bar is open (without rim), so that boxes can be drawn on or off.



	Order no.	Capacity kg	Wheel-Ø mm	Platform size L x W mm	Loading height mm	Type	Net weight kg
Euro box rollers	135800	250	125	605 x 405	182	open frame	11
	135810	250	125	605 x 405	182	with boards	13
	135820	250	125	605 x 405	209	with boards	14
	13587	250	125	605 x 405	182	open frame	11

Euro boxes on page 100

Accessories on pages 184-185



Euro box rollers

Compatible for Euro boxes
600 x 400 mm, powder coated
blue RAL 5007.

4 swivel castors with TPE tyres,
hubs with groove ball bearing.
2 wheels with locks.

Flat packed delivery.

13540

Roller with 2 platforms. Both
platforms of derived timber
material board housed in
frames, rim 15 mm high.
Clearance between platforms
400 mm, total height 638 mm.
Capacity of upper shelf 100 kg.



13540



13550

13550

As 13540, but platforms flush
with top edge of frame.
Capacity of upper shelf 100 kg.

135400

As 13540, but with tubular
push bar, total height 970 mm.
Capacity of upper shelf 100 kg.



135400



135500

135500

as 13550, but with tubular push
bar, total height 970 mm.
Capacity of upper shelf 100 kg.

135600

Roller with 2 shelf frames for
Euro boxes. Clearance between
shelf frames 500 mm, total
height 970 mm.

Capacity of upper shelf 80 kg.



135600



135610

135610

As 135600, but with shelves of
derived timber material board
housed in frames, rim 15 mm
high.

Capacity of upper shelf 80 kg.

	Order no.	Capacity kg	Wheel-Ø mm	Platform size L x W mm	Loading heights mm	Type	Net weight kg
Euro box rollers	13540	250	125	605 x 408	194, 623	with boards	17
	13550	250	125	605 x 405	209, 638	with boards	19
	135400	250	125	605 x 408	194, 623	with boards	18
	135500	250	125	605 x 405	209, 638	with boards	21
	135600	250	125	605 x 405	182, 712	open frames	15
	135610	250	125	605 x 405	194, 724	with boards	19

Euro boxes on page 100

**Accessories
on pages 184-185**



2380



2390



2381



2391



2382



2392

**Euro box carts
Modular system**

Tubular and sectional steel construction, bolted, powder coated.

4 swivel castors with TPE tyres, hubs with groove ball bearing, 2 wheels with locks.

Variable use of shelf frames, distance 50 mm, angle when inclined up to 15° and 30°.

Capacity per shelf 80 kg.

2380 | 2390

3 shelf-frames for 1 – 2 Euro boxes each 600 x 400 mm.

Delivery without boxes.

2381 | 2391

With 3 platforms made of derived timber material boards, rim 13 mm high.

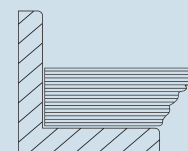

2382 | 2392

Open frames with 3 or 6 Euro boxes 600 x 400 x 145 mm.

	Order no.	Capacity kg	Wheel-Ø mm	Platform size L x W mm	Outside dimensions L x W x H mm	Type	Loading heights mm	Net weight kg
Euro box carts	2380	250	125	410 x 610	525 x 666 x 1101	open frames	238, 538, 838	27
	2390	250	125	820 x 610	935 x 666 x 1101	open frames	238, 538, 838	33
	2381	250	125	410 x 610	525 x 666 x 1101	with boards	251, 551, 851	35
	2391	250	125	820 x 610	935 x 666 x 1101	with boards	251, 551, 851	48
	2382	250	125	410 x 610	525 x 666 x 1101	with boxes	238, 538, 838	32
	2392	250	125	820 x 610	935 x 666 x 1101	with boxes	238, 538, 838	53

Euro boxes on page 100

Accessories
on pages 183-185
(No bigger wheel-Ø possible)



Euro box carts
Modular system

Euro box carts, tubular and sectional steel construction, bolted, powder coated blue RAL 5007.

4 swivel castors with TPE tyres, hubs with groove ball bearing, 2 wheels with locks.

Variable use of shelf frames, distance 100 mm, angle when inclined 15° and 30°.

Shelf heights:

300, 600, 900, 1200, 1500 mm

Capacity per shelf 80 kg.

1370

5 shelf-frames for every 2 euro boxes each 600 x 400 mm.

Delivery without boxes.

1371

With 5 platforms made of derived timber material boards, rim 13 mm high.

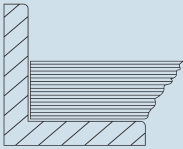

1372

with 10 euro boxes 1335, 600 x 400 x 145 mm.



1370



1371



1372

Euro boxes on page 100

Accessories
on pages 183-185

(No bigger wheel-Ø possible)

	Order no.	Capacity kg	Wheel-Ø mm	Platform size L x W mm	Outside dimensions L x W x H mm	Type	Loading heights mm	Net weight kg
Euro box carts	1370	400	160	820 x 610	935 x 666 x 1686	open frames	298, 598, 898, 1198, 1498	59
	1371	400	160	820 x 610	935 x 666 x 1686	with boards	311, 611, 911, 1211, 1511	84
	1372	400	160	820 x 610	935 x 666 x 1686	with boxes	298, 598, 898, 1198, 1498	68



1383



1384



1398



1399

**Euro box carts
Modular system**

Euro box carts, tubular and sectional steel construction, bolted, powder coated blue RAL 5007.

4 swivel castors with TPE tyres, hubs with groove ball bearing, 2 wheels with locks.

Variable use of shelf frames, distance 100 mm, angle when inclined 15° and 30°.

Shelf heights: 300, 600, 900, 1200, 1500 mm

Capacity per shelf 80 kg.

1383

5 shelf-frames for 3 euro boxes each 600 x 400 mm. Delivery without boxes.

1384

With 5 platforms made of derived timber material boards, rim 13 mm high.

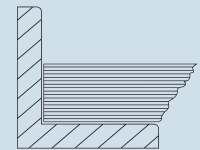

1398

With euro boxes
3 boxes 600 x 400 x 145 mm
6 boxes 600 x 400 x 170 mm
6 boxes 600 x 400 x 220 mm.

1399

With 15 euro boxes 1335, 600 x 400 x 145 mm.

	Order no.	Capacity kg	Wheel-Ø mm	Platform size L x W mm	Outside dimensions L x W x H mm	Type	Loading heights mm	Net weight kg
Euro box carts	1383	400	160	1240 x 610	1372 x 685 x 1686	open frames	298, 598, 898, 1198, 1498	70
	1384	400	160	1240 x 610	1372 x 685 x 1686	with boards	311, 611, 911, 1211, 1511	109
	1398	400	160	1240 x 610	1372 x 685 x 1686	with boxes	298, 598, 898, 1198, 1498	97
	1399	400	160	1240 x 610	1372 x 685 x 1686	with boxes	298, 598, 898, 1198, 1498	96

Euro boxes on page 100

Accessories
on pages 183-185
(No bigger wheel-Ø possible)



Storage trolleys Modular system

Tubular steel and steel section construction, powder coated.

2 swivel and 2 fixed-wheel castors, TPE tyres, 125 x 32 mm, hubs with groove ball bearing.

Swivel castors with wheel locks.

Capacity upper and middle shelf 50 kg.

32900 | 32910

Open frames without board.

Loading heights:
197, 652, 1152 mm



32900



32910

32901 | 32911

With 3 platforms made of derived timber material boards, rim 13 mm high.

Loading heights:
209, 664, 1164 mm

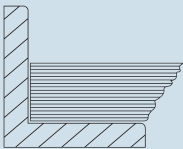

32901



32911

32902 | 32912

With 3 plastic boxes,
1 pc. 600 x 400 x 145 mm
2 pcs. 600 x 400 x 220 mm.

Loading heights:
197, 652, 1152 mm



32902



32912

32910 | 32911 | 32912

Storage trolley with tiltable surfaces. Upper and middle platform tiltable to both sides by 15° and 30°, locked by spring catch.

Euro boxes on page 100

Accessories
on pages 183-185

	Order no.	Capacity kg	Wheel-Ø mm	Platform size L x W mm	Outside dimensions L x W x H mm	Type	Net weight kg
Storage trolleys	32900	200	125	605 x 405	821 x 455 x 1178	open frames	22
	32910	200	125	605 x 405	821 x 455 x 1178	open frames	24
	32901	200	125	605 x 405	821 x 455 x 1178	with boards	31
	32911	200	125	605 x 405	821 x 455 x 1178	with boards	33
	32902	200	125	605 x 405	821 x 455 x 1282	with boxes	28
	32912	200	125	605 x 405	821 x 455 x 1282	with boxes	30



32920



32921



32930



32931

**Storage trolleys
Modular system**

Made of tubular and sectional steel, welded and powder coated blue RAL 5007, bolted construction.

2 swivel and 2 fixed-wheel castors, TPE tyres, 125 x 32 mm, hubs with groove ball bearing.

2 wheels with locks.

Loading heights:
285, 540, 795, 1050 mm

Capacity per shelf 60 kg.

32920

4 shelves of derived timber board, rim 10 mm high.

32921

Design as 32920, but additionally with 4 storage boxes 1786, dimensions L x W x H: 500/450 x 310 x 200 mm.

32930

4 shelves of derived timber board, rim 10 mm high.

32931

Design as 32930, but additionally with 8 storage boxes 1786, dimensions L x W x H: 500/450 x 310 x 200 mm.

	Order no.	Capacity kg	Wheel-Ø mm	Platform size L x W mm	Outside dimensions L x W x H mm	Type	Net weight kg
Storage trolleys	32920	250	125	320 x 470	430 x 513 x 1130	with boards	24
	32921	250	125	320 x 470	430 x 513 x 1250	with boxes	29
	32930	250	125	630 x 470	740 x 513 x 1130	with boards	32
	32931	250	125	630 x 470	740 x 513 x 1250	with boxes	43

**Storage boxes
on page 100**



Storage trolleys Modular system

Made of tubular and sectional steel, welded and powder coated blue RAL 5007, bolted construction.

2 swivel and 2 fixed-wheel castors, TPE tyres, 125 x 32 mm, hubs with groove ball bearing.

2 wheels with locks.

Loading heights:

285, 540, 795, 1050 mm

Capacity per shelf 60 kg.

32940

4 shelves of derived timber boards, rim 10 mm high.



32940

32941

Design as 32940, but additionally with 12 storage boxes 1786, dimensions L x W x H: 500/450 x 310 x 200 mm.

32950

4 shelves of derived timber board, rim 10 mm high.

32951

Design as 32950, but additionally with 16 storage boxes 1786, dimensions L x W x H: 500/450 x 312 x 200 mm.



32950



32941



32951

Storage boxes
on page 100

	Order no.	Capacity kg	Wheel-Ø mm	Platform size L x W mm	Outside dimensions L x W x H mm	Type	Net weight kg
Storage trolleys	32940	250	125	940 x 470	1050 x 513 x 1130	with boards	42
	32941	250	125	940 x 470	1050 x 513 x 1250	with boxes	58
	32950	250	125	1250 x 470	1360 x 513 x 1130	with boards	50
	32951	250	125	1250 x 470	1360 x 513 x 1250	with boxes	71



2881



2882



2883



2884



2891



2892

Assembly trolleys

Modular system

Made of tubular and sectional steel, welded and powder coated blue RAL 5007, bolted construction.

4 swivel castors with TPE tyres 125 x 32 mm, hubs with groove ball bearing.

Variable use of shelves, steel frame with inserted derived timber material board, surface beech grain, 12 mm high skirting. Distance 100 mm, angle continuously adjustable of 0° to 35°. Secure locking by handle screws.

Capacity per shelf 60 kg.

German Patent
10 2005 062 391

2881 | 2883

One-sided construction, 3 shelves made of derived material timber board, 12 mm high skirting.

2882

Construction as 2881, but additionally with 12 storage boxes; dimensions L x W x H 230/200 x 147 x 132 mm and 4 boxes 350/300 x 210 x 145 mm.

2884

Construction as 2883, but additionally with 12 Euro boxes size L x W x H 400 x 300 x 145 mm.

2891

Two-sided construction, two-part shelves made of derived material timber board, 12 mm high skirting.

2892

Construction as 2891, but additionally with 16 storage boxes; dimensions L x W x H 230/200 x 147 x 132 mm and 24 boxes 350/300 x 210 x 145 mm and 12 boxes 350/300 x 210 x 200 mm.

Additional shelves

Add. shelf for	Order no.
2881 2882	2888
2883 2884	2899
2891 2892	2898

Order no.	Capacity kg	Platform size L x W mm	Outside dimensions L x W x H mm	Type	No. of shelves	Loading heights mm	Net weight kg
2881	250	900 x 315	1050 x 362 x 1205	with boards	3	370, 670, 970	33
2882	250	900 x 315	1050 x 362 x 1205	with boxes	3	370, 670, 970	40
2883	250	1240 x 415	1355 x 477 x 1197	with boards	3	370, 670, 970	46
2884	250	1240 x 415	1355 x 477 x 1197	with boxes	3	370, 670, 970	56
2891	300	1280 x 2 x 315	1420 x 740 x 1530	with boards	4	370, 670, 970, 1270	96
2892	300	1280 x 2 x 315	1420 x 740 x 1530	with boxes	4	370, 670, 970, 1270	123

Euro and Storage boxes on page 100

Storage boxes**1781 - 1786**

Made of robust impact-resistant synthetic material, smooth surface and therefore easy to clean. Colour grey.

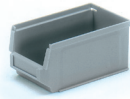

1781



1782



1783



1784



1786

Euro boxes**1308 - 1339**

In standard Euro dimensions, made of high-quality, shock-resistant plastic, mainly Polyethylene (PE) and Polypropylene (PP). These materials are resistant to all common alkaline solutions and acids, neutral to smell and taste, physiologically recognized as safe and remain in the temperature range between -40° and $+100^{\circ}$ stable as far as dimensions and material is concerned. Colour grey.



1309



1335



1330



1336



1339



1308



1337



1315 | 1338

Cover for euro boxes**1315 | 1338**

Hinge lid with 2 spring locks, lid can be security-sealed.

	Order no.	Outside dimensions L x W x H mm	Inside dimensions L x W x H mm	Content litres	Capacity kg	Net weight kg
Storage boxes	1781	170/145 x 102 x 78	–	–	1	0,1
	1782	230/200 x 147 x 132	–	–	3,2	0,3
	1783	350/300 x 210 x 145	–	–	8	0,6
	1784	350/300 x 210 x 200	–	–	10,5	0,8
	1786	500/450 x 310 x 200	–	–	24,5	1,4
Euro boxes	1309	400 x 300 x 145	366 x 264 x 130	12	15	0,9
	1335	600 x 400 x 145	558 x 358 x 142	28	20	1,6
	1330	600 x 400 x 170	558 x 358 x 165	33	20	3,3
	1336	600 x 400 x 220	558 x 358 x 216	43	20	1,8
	1339	600 x 400 x 280	558 x 358 x 275	55	20	2,3
	1308	600 x 400 x 325	558 x 358 x 320	64	20	3,8
	1337	600 x 400 x 425	570 x 370 x 422	89	20	3,6
Cover	1315	400 x 300	–	–	–	0,4
	1338	600 x 400	–	–	–	0,7

MOBILE TILTING STANDS

High quality:

Robust steel structure and resilient powder coating. Made in Germany



4 high-quality castors:

For easy movement and optimal manoeuvrability. 2 of them with locks.

Individual:

Various platform and adjusting systems.



Ergonomic:

Less stress on the spine while work standing or sitting. Adjustable in height.



Mobile tilting stands

For plastic boxes, steel plate boxes, wire baskets etc., adjustable in height and mobile.

Sectional steel-/ tubular construction with steel plate platform. Powder coated blue RAL 5007. 4 swivel castors with TPE tyres, hubs with bush bearing, 2 wheels with locks.

3260 | 3270

Steel plate platform with all side rim, 20 mm high. Not inclinable, adjustable in height in intervals of 25 mm.



3260



3270

3280 | 3282

Steel plate platform with single-sided lay-on edge, straight or inclinable by 15° und 30°, adjustable in height in intervals of 25 mm.



3280



3282



Example of use

	Order no.	Capacity kg	Wheel-Ø mm	Platform size L x W mm	Height adjustable from - to mm	Net weight kg
Mobile tilting stands	3260	150	75	605 x 405	524-774	17
	3270	150	75	605 x 405	720 - 995	17
	3280	150	75	510 x 410	500 - 775	18
	3282	150	75	510 x 410	755 - 1105	18



3285



3286



3290



3291



3191

Mobile tilting stands

For plastic boxes, steel boxes, wire baskets etc., adjustable in height and mobile.

Sectional steel-/ tubular construction with steel plate platform. Powder coated blue RAL 5007. 4 swivel castors with TPE tyres, hubs with bush bearing, 2 wheels with locks.

3285

Steel plate platform with single-sided lay-on edge, straight or inclinable by 15° and 30°, continuously adjustable in height via rack and pinion jack, even under load. 2 telescopic pillars.

3286

Steel plate platform with single-sided lay-on edge, straight or inclinable by 15° und 30°, continuously adjustable in height via hydraulic pump, even under load. Operated via pedal, precisely adjustable via lowering valve.

3290 | 3291

Steel plate platform with single-sided lay-on edge, straight or inclinable by 15° und 30°, continuously adjustable in height, rotatable and lockable, with pneumatic lowering damping.

Roller support

3191

To support long materials on saws, presses, drills etc. Continuously adjustable in height, rotatable and lockable, with pneumatic lowering damping. Mobile. Supporting roller of tubular steel 450 mm, 60 mm Ø, ball bearing mounted. Loose gravity-stops on both sides 20 mm above top edge of roller (automatically turn away for wide work pieces).

4 swivel castors with locks. Flat packed for easy self assembly.

	Order no.	Capacity kg	Wheel-Ø mm	Platform size L x W mm	Height adjustable from - to mm	Net weight kg
Mobile tilting stands	3285	250	125	750 x 450	655 - 1025	35
	3286	250	125	750 x 450	720 - 1080	39
	3290	150	75	510 x 410	510 - 700	24
	3291	150	75	510 x 410	720 - 1070	28
Roller support	3191	150	75	-	780 - 1130	21

Disassembled delivery, easy self-assembly. Warranty for 3286, 3290/3291 and 3191 2 years.

SHELVED TROLLEYS WITH DETACHABLE SHELVES



Patented Insert-and-Bolt principle:
Shelves can be inserted into a 120 mm grid, either horizontally or at an incline of 15° or 30°. Easily installed without tools by one person.



Shelves:
With 15 mm high rim made of angle steel on the longitudinal sides.



TPE castor:
The innovative easy-running TPE-castor in the attractive fetra design is non-marking and odourless. Particularly smooth-running groove ball bearing.



Alternatively with wire lattice:
Permeable and insensitive to dirt.





4295 | 4296



4255 | 4256



4395 | 4396



4495 | 4496

Shelved trolleys with detachable shelves

with horizontal or inclined, detachable shelves.

Tubular/sectional steel design, powder coated.

Fixed and detachable shelves made of derived timber material boards, surface beech gain, put into an angle steel frame with 15 mm high skirting at both sides. Detachable shelves variably insertable, distance between support rods 120 mm. Possible angle when inclined 15° or 30°.

2 swivel and 2 fixed-wheel castors, TPE tyres 200 x 40 mm, hubs with groove ball bearing.

Swivel castors with wheel locks.

Capacity per shelf 80 kg.

German Patent 102 55 281

4495 | 4496

as above, but with fixed and detachable shelves with welded wire lattice 140 x 40 mm, powder coated blue RAL 5007.

Capacity per shelf 50 kg.



	Order no.	Capacity kg	Wheel-Ø mm	Platform size L x W mm	Outside dimensions L x W x H mm	No. of shelves	Net weight kg	Add. shelves	
								Order no.	
Shelved trolleys	4295	500	200	1250 x 610	1430 x 620 x 1560	3	68	E4195ET	
	4296	500	200	1650 x 610	1830 x 620 x 1560	3	85	E4196ET	
	4255	500	200	1250 x 610	1430 x 620 x 1560	4	83	E4195ET	
	4256	500	200	1650 x 610	1830 x 620 x 1560	4	105	E4196ET	
	4395	500	200	1250 x 610	1430 x 620 x 1800	4	86	E4195ET	
	4396	500	200	1650 x 610	1830 x 620 x 1800	4	108	E4196ET	
	4495	500	200	1250 x 610	1430 x 620 x 1800	4	73	E4495ET	
	4496	500	200	1650 x 610	1830 x 620 x 1800	4	87	E4496ET	